

GZ1950 Heavy Duty Stanchion

with Standard Width Webbing

Perfect for indoor and outdoor use. Features a heavy duty base with easy carry handles. Ideal for health and safety applications

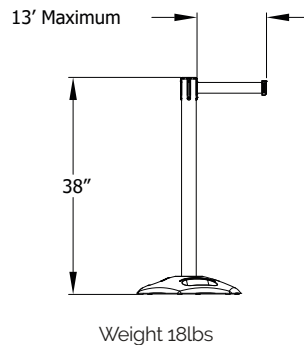
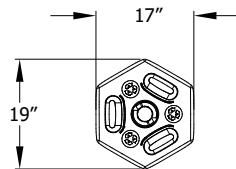
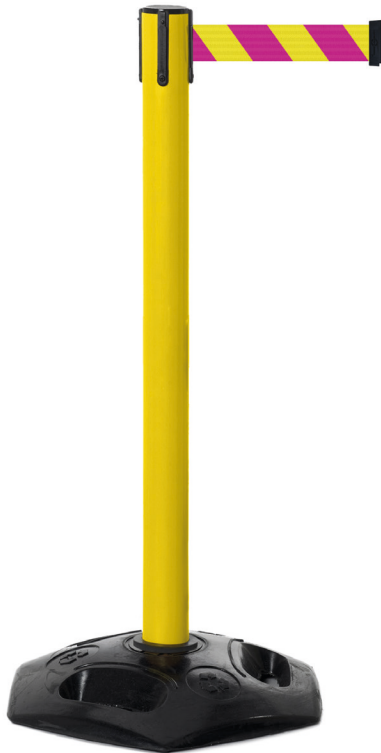
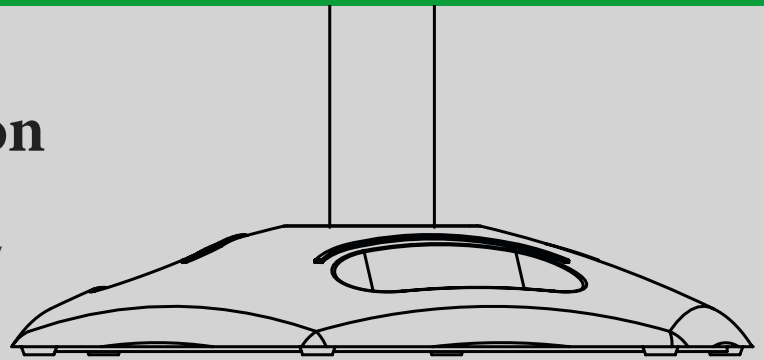

Features & Benefits

- The facility post features a lightweight plastic post that screw fixes into a recycled rubber heavy duty base.
- The post and base can be quickly and easily dismantled for easy storage and transportation.
- The robust base can be walked or driven over and it will still retain its shape and function.
- Ideal for indoor and outdoor use, but shouldn't be permanently placed outside.
- The safest barrier on the market – our cassettes have a unique braking system for slower webbing retraction.

Product Specification

- Plastic post available in 4 UV stable colors.
- Black recycled rubber base with easy carry handles, which allows for the post to be easily screwed into place.
- Shipped flat packed with no tools required.
- Available with any Tensator® standard (2") webbing options.
- Modular webbing cassette – all cassettes come as standard with our four-point anti-tamper webbing connectivity. This allows you to connect other Tensabarrier® products to the receiver splines on the cassette head.
- Compatible with all Tensabarrier® accessories including our range of post top signage.
- Available to buy in a twin pack.

Applications

- Eliminate unsafe working conditions by clearly defining routes.
- Restrict access to dangerous areas.
- Use to identify hazards before they cause harm.
- Ideal for warehouses, industrial and maintenance areas.
- Indoor and outdoor use.

Product Configuration

Post Finishes

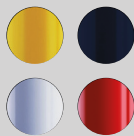

Four plastic finishes available.

Webbing Options



Standard Webbing Dual Line

2" width 2" width (each line)

Webbing Lengths



2" width 2" width

Webbing Designs



Range of colors, designs and custom options.

Tape End Options

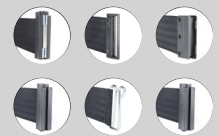

Six tape end options available.